

PWBat10

1000mAh Li-Pol battery

Description Li-Pol battery characteristics

Document version	Date	Version	Changes
	December 2009	1.0	Initial version.

Introduction

In recent years, Li-Pol batteries are gaining momentum. Although they still suffer from a bad reputation of being unsafe, and potentially causing explosions / fires, the number of cases every year doesn't exceed a few hundreds worldwide. Furthermore, part of these cases are due to short-circuit or overload.

The batteries we provide can be considered as safe since they have an integrated charge / discharge monitor chip.

Disclaimer

Before buying our batteries, the user agrees he has been informed about the following issues:

1. PassWorld YK will not take any responsibility in case of fire or explosion.
2. There can be capacity disparities.

Characteristics

The following characteristics have been verified.

However, no aging test have been made so far.

PW-LiPol-010	1000mAh Li-Pol battery
	<p>寸法 : 35.5 x 53.8 x 5.5 mm</p> <p>容量 : 約1000mAh (以下の放電はLED+抵抗を使用し得られたデータ。初期電流は14mA。80時間の電流は11mA位)</p> <p>このバッテリーは充電回路を内装し、5VDC (USB等) を与えると充電され、充電は自動的に止まる。</p> <p>バッテリー付属品 : 表面実装コネクタ。</p>

Discharge characteristics

The following curve is based on our experiment. We can therefore conclude that the capacity is approximately what the battery maker claims. The blue curve shows that the discharge amount at 3.7 V is approximately 960 mA. The red curve shows the voltage corresponding to the discharge amount. The horizontal axis shows time in hours. If the powered system can accept lower voltages, the capacity exceeds 1000 mAh,

— Voltage (V) — Discharge amount (Ah)

LIPOL-1000mAh discharge characteristics

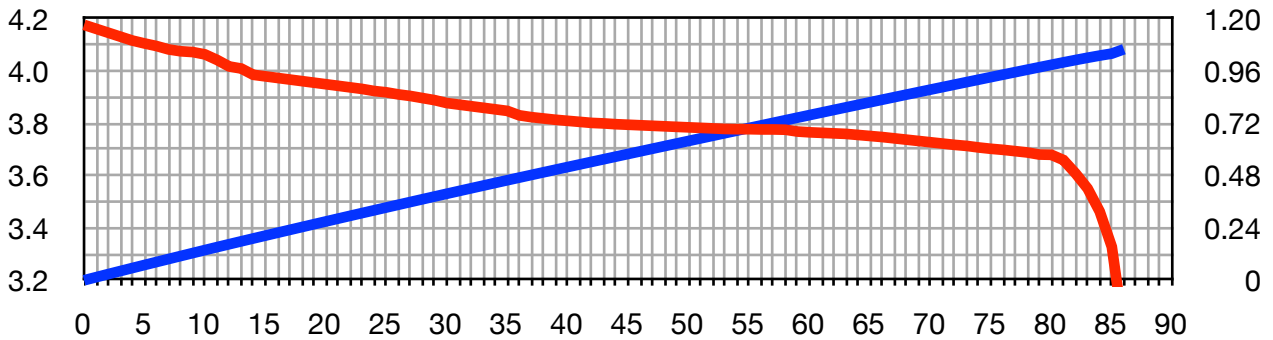

Charging the battery

As this battery has an internal charge chip, it can be connected directly to a 5V source, for instance USB.

Measurement and test device example

The following test system was used for measurements:

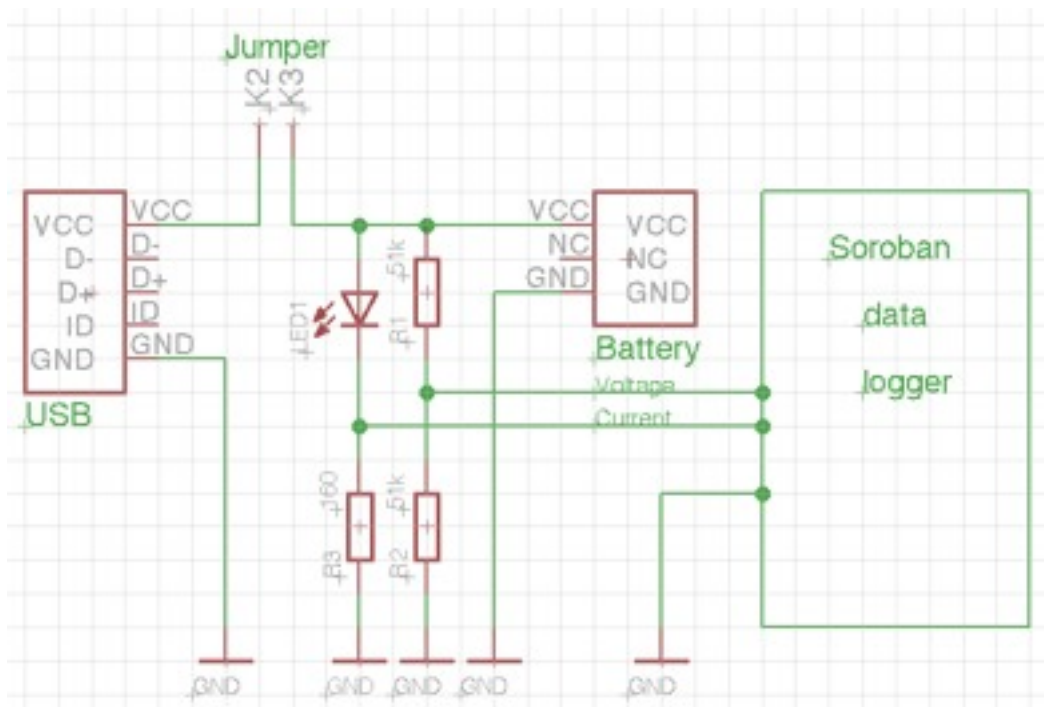

The jumper was used to verify the consistency of the measured current. The diode and its serial resistor were mounted in sockets. By replacing the diode and its serial resistor, it is possible to draw greater currents. Note that the battery is directly charged using the USB interface. Since USB can output 500 mA, the battery can be charged in 2 hours.

The following picture shows an implementation of the circuit described above.

